



Infinite  
Peripherals

LINEA PRO 5

USER MANUAL



# LINEA PRO 5

iPhone®/iPod touch® 1D/2D SCANNER

Made for



iPod



iPhone

# ***CONTACT INFORMATION***

**Mobility Sales/Technical Center:** Infinite Peripherals, Inc.  
1641 McGaw Avenue  
Irvine, CA 92614  
**Toll Free:** (866) 278-7860  
**Office:** (949) 222-0300  
**Fax:** (949) 222-0375

**Headquarters/Main Warehouse:** Infinite Peripherals, Inc.  
2312 Touhy  
Elk Grove Village, IL 60004  
**Toll Free:** (800) 278-7860  
**Phone:** (847) 818-1260  
**Fax:** (847) 818-1287

**Technical Support:** Infinite Peripherals, Inc.  
1641 McGaw Avenue  
Irvine, CA 92614  
**Toll Free:** (866) 278-7860  
**Office:** (949) 222-0300  
**Fax:** (949) 222-0375  
**Email** [info@ipcprint.com](mailto:info@ipcprint.com)  
**ipcprint.com**



**Infinite  
Peripherals**

## ***LEGAL NOTICE***

---



“Made for iPod,” and “Made for iPhone,” mean that an electronic accessory has been designed to connect specifically to iPod, or iPhone respectively, and has been certified by the developer to meet Apple performance standards. Apple is not responsible for the operation of this device or its compliance with safety and regulatory standards. Please note that the use of this accessory with iPod, or iPhone may affect wireless performance.

## ***COMPATABILITY***

Made for

iPod touch 5<sup>th</sup> generation

iPhone 5

iPad, iPhone and iPod touch are trademarks of Apple Inc., registered in the U.S. and other countries. Lightning is a trademark of Apple Inc.

# **CONTENTS**

---

Compatability	1
Overview	3
Technical Data	4
Box Contents	5
Getting Started	6
About Your Linea Pro 5	7
Charging Your Linea Pro 5	8
Status and Operational Modes	9
Features – 1D Barcode Scanning	10
Features – 2D Barcode Scanning	11
Features – Magnetic Card Reader	12
Features – RFID Cards	13
Syncing	14
Replacing Battery	15
Developing Applications	16
SRED Encrypted MSR Information	17
Troubleshooting – Card Reading	18
Troubleshooting – Barcode Scanning	19
Troubleshooting - RFID Reading/Writing	20
Federal Communications Commission	21

# OVERVIEW

---

The Linea Pro 5 allows mobile employees to convert their iPod or iPhone into a powerful solution for retail, warehousing, supply chain, ticketing and hospitality industries. The Linea Pro 5 includes an encrypted or unencrypted 3-track magnetic stripe reader, optional 1D or 2D barcode scanner, optional Bluetooth, and optional RFID.

## FEATURES

- Battery**      Rechargeable Li-ion Battery - 1300 mAh
- Charging via USB to computer or Charging Station to Linea Pro 5, provides auxiliary power to iPod touch and iPhone
- Magnetic Card Reader**
- 3-Track Head
- Swipe Speed: Minimum of 1.97 in/sec
- MTBF: 1 million swipes
- Bidirectional reading capabilities
- Barcode Scanner**
- Class II - 1D Laser / 2D Imager:
- Single / Multi-scan mode
- 1D - MTBF: 30K hours (Laser Diode & Mirror Unit 10K hours)
- 2D - MTBF: 50K hours (Imager & Laser Pointer & Focus LED)
- RFID**            MIFARE MINI
- MIFARE CLASSIC-1K, MIFARE CLASSIC-4K
- MIFARE ULTRALIGHT, ULTRALIGHT-C
- ISO 14443, ISO 15693
- MIFARE PLUS 2K/4K
- DESFire card
- I/O Connectors**
- 9-pin Lightning Connector
- 10-pin female Mini-B USB connector for charging and synchronization
- Indicators**    Audible: Internal electro-magnetic buzzer
- Visual: 4 green LEDs

# TECHNICAL DATA

## GENERAL SPECIFICATIONS

Power Supply	Internal Voltage 3.3V and 5V
Compatibility	iPhone 5 or iPod touch 5
Communications	USB Interface - between Linea Pro 5 and iPhone 5/iPod touch 5 USB Synchronization between iPhone 5/iPod touch 5 & PC
Power Consumption	Deep sleep ~20uA
Buttons	1 Scanning Button
Magnetic Stripe Reader	3-track bidirectional reading capabilities Type: ISO 7816-1/2/3 compatible & RAW mode PCI PTS 3.x SRED compliant DUKPT and Fixed Key Management 3DES-112, AES-128, AES-256 encryption algorithms
Certification, Encryption and Key Management	PCI PTS 3.x SRED compliant DUKPT and Fixed Key Management 3DES-112, AES-128, AES-256 encryption algorithms
Barcode Scanner	1D Laser or 2D High Speed Imager
Barcode Type	UCC/EAN 128, EAN 13, EAN 8, UPC A, UPC E, UPC E1, Code 11, Code 39, Code 93, Code 128, GS1, Matrix 2 to 5, Code 11, 2 of 5 industrial, 2 of 5 interleaved, Codebar, MSI/Plessey, UK/Plessey, IATA, ISBN, ISMN, ISSN, S-code, Telepen, RSS 14, RSS Limited, RSS-Expanded, PDF417, microPDF417, Data Matrix, QR code, Aztec code, Maxi code, Micro QR code
RFID Reader (optional)	MIFARE MINI MIFARE CLASSIC-1K, MIFARE CLASSIC-4K MIFARE ULTRALIGHT, ULTRALIGHT-C ISO 14443, ISO 15693 MIFARE PLUS 2K/4K DESFire card
Bluetooth Communication (optional)	Bluetooth 1.1 Class 2 distance - Up to 10m Serial port profile
LED	4 LEDs for battery status
Battery	Rechargeable Li-ion Battery 3.7V 1300mAh, charging from USB port
Audio Indicator	Electromagnetic Buzzer
Weight	120 grams
Dimensions	1D scanner 142mm x 69mm x 22mm 2D scanner 142mm x 69mm x 27mm
Operating Environment	- Operating temperature: 0°C to +40°C - Operating humidity: 35 to 85% RH - Storage temperature: -5°C to +40°C - Storage humidity: 10 to 90% RH
Cables	Standard USB A to mini B cable

\*Specifications subject to change without notice.

## **BOX CONTENTS**

---

Your Linea Pro 5 will ship with the items listed below.

Linea Pro 5

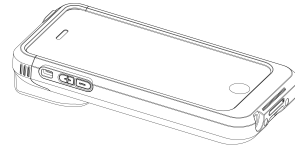

USB charge / sync cable\*



\*Bulk shipments may ship without cables in each box

### **SOFTWARE: DRIVERS & SDK**

Because of the continually evolving SDK, the latest SDK are not distributed on CD.

For the latest Linea Pro 5 SDK's, please visit our developer portal:

[www.ipcprint.com/developer](http://www.ipcprint.com/developer)

# GETTING STARTED

---

The Linea Pro 5 allows customers to scan barcodes and capture magnetic strip information into the iPod and iPhone. Before using your Linea Pro 5 the battery should be properly charged. The following table will help to get your Linea Pro 5 ready for use.

## QUICK START GUIDE

Step	What to do	Purpose	Where to find more information
1	Fully charge your Linea Pro 5 as recommended	The battery pack should be fully charged before use to ensure long battery life.	Charging Battery, Page 8.
2	Install Software	Barcode Scanning & Card Reading requires software to be installed onto your iPod or iPhone.	Software is not provided with Linea Pro 5. Please contact your reseller or Infinite Peripherals for suggestions on Third-Party software solutions.  Developers should refer to the section in this manual on "Developing Solutions" Page 18.
3	Attach device to Linea Pro 5	Connecting your Linea Pro 5	Charging Battery, Page 8



## ABOUT YOUR LINEA PRO 5

---

1. On/Off
2. Scan Button
3. Scan Engine
4. Volume Controls
5. USB Sync/Charge Port
6. Audio Connector

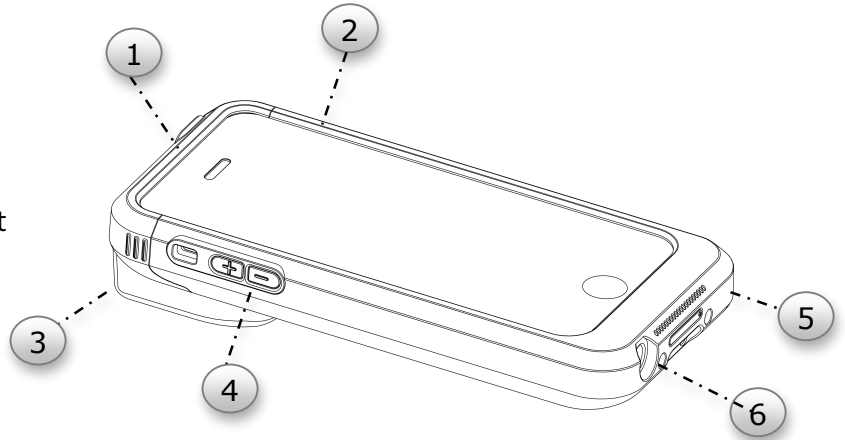

### Linea pro 5 - Bottom Side

1. On/Off
2. Scan Button
3. Scan Engine
4. Magnetic Stripe Reader

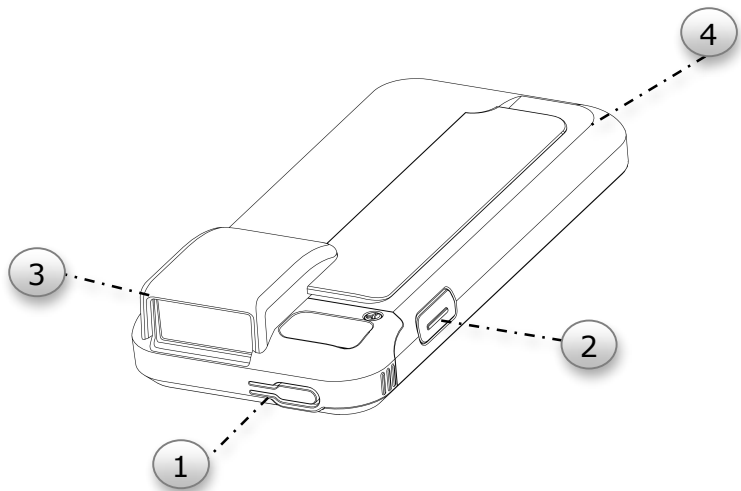

### User Notes

Special software must be used to process the information captured by the barcode scanner and magnetic stripe reading feature. Please consult your reseller for this software or contact Infinite Peripherals for recommendations on compatible third party software solutions.

## **CHARGING YOUR LINEA PRO 5**

---

Charging the Linea Pro 5 through the USB port:

The Linea Pro 5 uses a Lithium Ion rechargeable battery. Before first use, the battery pack should be charged for at least (4) hours.

To prevent electrical damage to the Linea Pro 5 and/or battery, please use approved USB to Mini USB cables only.

1. Connect mini USB charger cable as shown below.

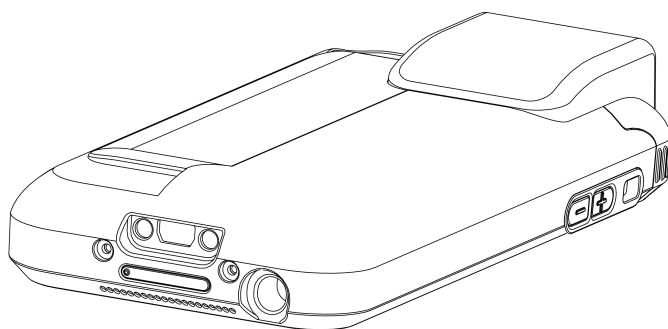
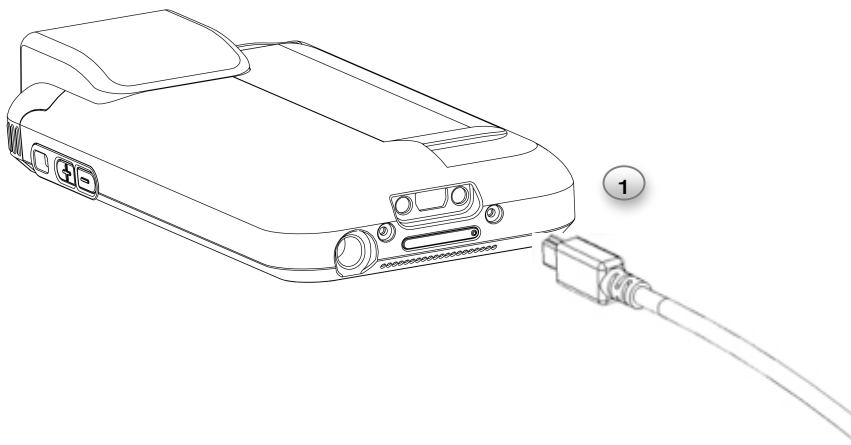

1 LED = 25% of full charge  
2 LED = 50% of full charge  
3 LED = 75% of full charge  
4 LED = 100% of full charge

## **STATUS AND OPERATIONAL MODES**

---

The Linea Pro 5 uses the battery indicator LEDs to indicate various conditions of operation. Possible LED lighting indications may result from charging, active/online status, or because of low battery. The following table and figure explain these conditions and LED indication.

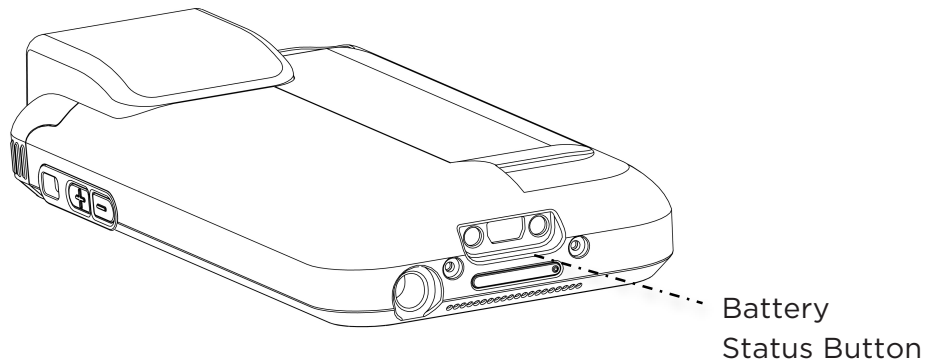

### **Operating Status**

All LED is OFF	Linea Pro 5 is in sleep or ready mode
Middle LED is FLASHING	Linea Pro 5 is in sync mode
Multiple LED is ON	Linea Pro 5 is displaying battery level status

## **FEATURES - 1D BARCODE SCANNING**

---

### Using the 1D Barcode Scanner

The Linea pro 5 1D model uses a scan engine that supports one-dimensional (1D) barcode symbols. The effective reading distance of the barcode reader varies depending on the barcode size.

### Scanning 1D Barcodes

To scan a 1D barcode first activate the scanner. Then position the scan head as close to the barcode label as possible so that the scan line crosses both ends of the barcode as shown in the figure below.

Slowly pull back the unit increasing the distance between the barcode and scan head until the barcode has been read by the scanner.

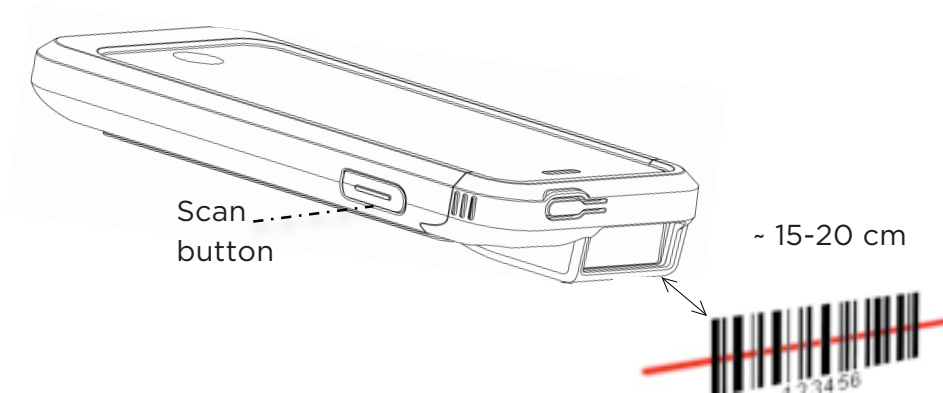

## **FEATURES - 2D BARCODE SCANNING**

---

### Using the 2D Barcode Scanner

The Linea Pro 5 2D model uses a scan engine that supports one-dimensional (1D) and two-dimensional (2D) barcode symbols. The effective reading distance of the barcode reader varies depending on the barcode size.

### Scanning 2D Barcodes

To scan a 2D barcode first activate the scanner. Then position the scan head so that the light green rectangle is aimed at the barcode and the barcode is within the width of the red illumination box.

Slowly pull back the device which increases the distance between the barcode and scanner until the barcode has been read by the scanner.

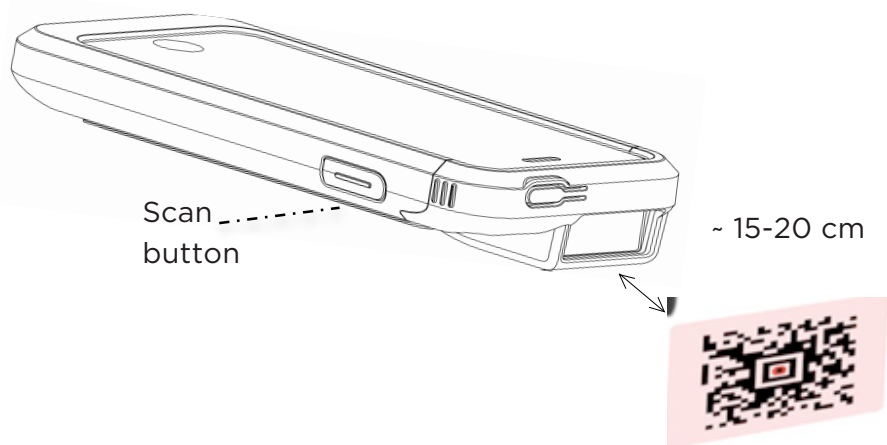

## **FEATURES - MAGNETIC CARD READER**

---

The Linea Pro 5 has a built-in magnetic card reader. The card reader incorporates a (3) track magnetic read head requiring a single swipe to read field data from all three tracks.

The magnetic read head faces up towards the top of the cradle. When placing the card into the reader, the magnetic strip must be facing up as shown in the figure below. Keep the edge of the card flat on the inner base of the reader to ensure that the magnetic strip passes over the read head evenly.

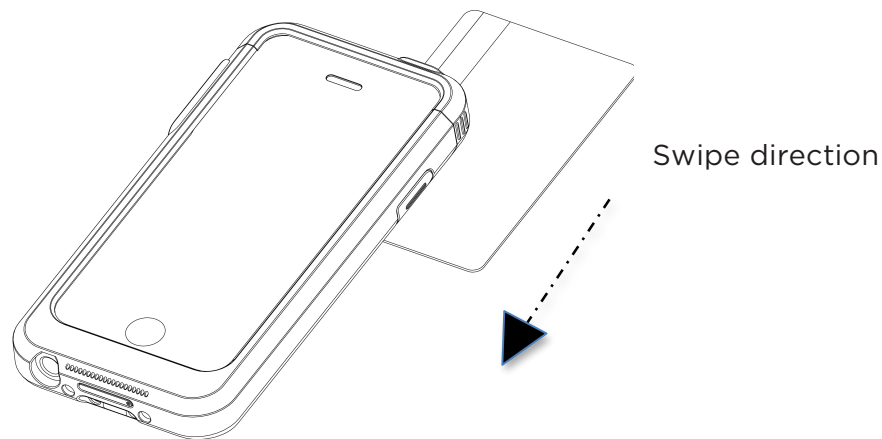

### User Notes

To use the magnetic card reader feature, special software must be used to read and process the card information. Please consult your reseller if this software is available or contact Infinite Peripherals for recommendations on compatible third party software solutions.

## **FEATURES - RFID CARDS**

---

### Reading RFID Cards

The Linea Pro 5 has a built-in RFID tag/card reader. The RFID reader incorporates several RFID format depending on the model of your Linea Pro 5.

To Read/Write to RFID tag/cards will require special software not included with the Linea Pro 5

Place the RFID tag/card over the receiver/transmitter. Keep the face of the tag/card flat with the receiver/transmitter as close as possible.

### **Tips:**

Depending on the type of RFID tags/cards being used, it may be necessary for tags/cards to make direct contact with the surface where the RFID receiver/transmitter is located for proper reading/writing.

## ***SYNCING***

---

The Linea Pro 5 portable barcode scanner and card reader is designed specifically for use with iPod/iPhone there by allowing the iPod and iPhone to sync with iTunes through the Linea Pro 5 while connected.

To sync iPod with iTunes through the Linea Pro 5 follow the steps below;

1. Connect the Linea Pro 5 to a computer using a Mini USB cable as shown in the figure below.
2. Wait for the sync mode 2-beeps and the center LED flashes green.

The Linea Pro 5 should now be in sync mode. Refer to the iTunes documentation for syncing your iPod and iPhone.

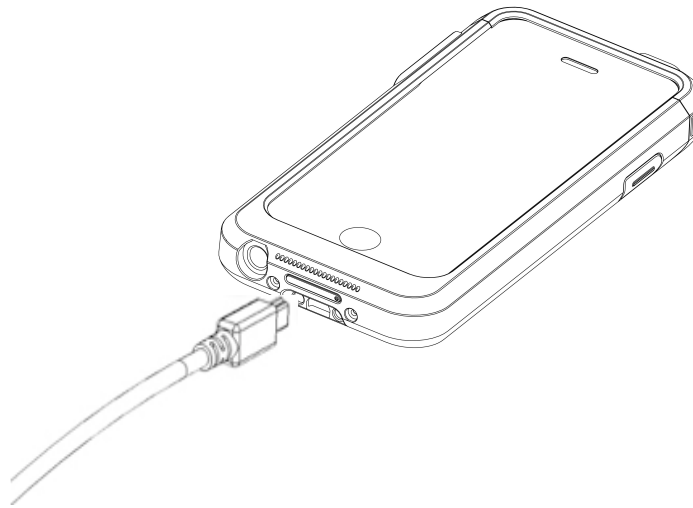

To disable sync mode, exit iTunes then unplug the Linea Pro 5 from the Mini USB cable.



## **REPLACING BATTERY**

---

The Linea Pro 5 is designed with an internal Lithium Ion rechargeable battery pack.

For problems related to battery not charging or unit not turning on, please consult your Infinite Peripheral representative or certified service center.

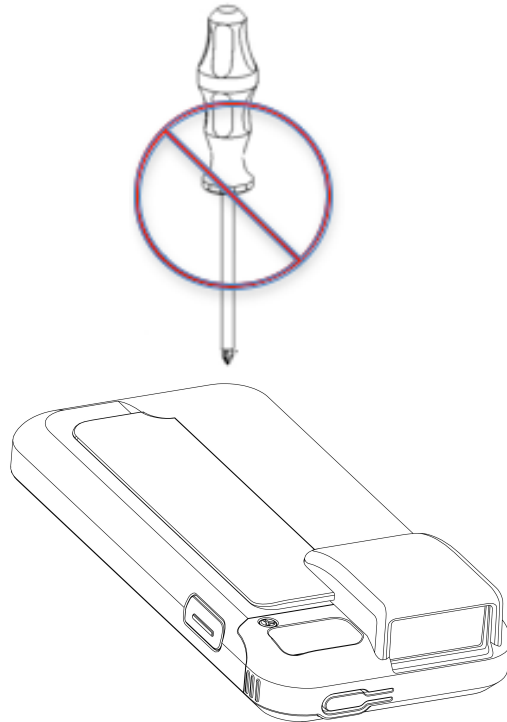

### **Warning:**

- Disassembling of the Linea Pro 5 may impact your Linea Pro 5 warranty. Please consult your Infinite Peripheral representative before attempting to open the Linea Pro 5.
- Attempting to disassemble a SRED encrypted Linea Pro 5 device will render the unit unusable. Please consult your Infinite Peripheral representative or certified service center.

## ***DEVELOPING APPLICATIONS***

---

Integrating the Linea Pro 5 into your app requires the use of the Linea Pro 5 SDK. The SDK incorporates an API specifically for developing applications to use the barcode scanning and card reading capability of the Linea Pro 5.

For details on using the Linea Pro 5 SDK, please refer to the SDK's documentation.



For the latest Linea Pro 5 SDK's, please visit our developer portal.

<http://www.ipcprint.com/developer/>

## ***SRED ENCRYPTED MSR INFORMATION***

---

Integrating the PCI PTS 3.x SRED certified Linea Pro 5 into your solution requires proper maintenance of the Linea Pro 5 to insure long and trouble free operation of the product.

This includes maintaining proper battery charge to prevent the Linea Pro 5 from entering tamper detect mode. When the Linea Pro 5 battery runs out or if the battery is removed the magnetic read head security feature becomes disabled and renders the unit unusable. This will require the unit to be sent back to Infinite Peripherals for servicing.

To prevent down time caused by the magnetic read head security feature becoming disabled follow the recommendations below:

- Do not allow the Linea Pro 5 battery to fully discharge.
- Do not attempt to remove battery from Linea Pro 5 unit.
- Always place the Linea Pro 5 on charging station when not in use for extended periods.

The battery capacity and approximate time remaining before full discharge are shown in the table below. These values do not include daily usage of your Linea Pro 5 and iOS device:

<b>Configuration</b>	<b>Linea Pro 5 Fully Charged</b>
With iOS device	2,708 days
Without iOS device	2,708 days

### **Warning:**

- When the Linea Pro 5 battery is fully discharged and enters the tamper detect mode, the unit can only be re-enabling at an IPC authorized service facility or at one of IPC's location

## ***TROUBLESHOOTING - CARD READING***

---

If you are having a problem reading the magnetic strip refer to the table below for possible causes.

<b>Item</b>	<b>Problem</b>	<b>Possible Cause</b>
1	No card data returned during swiping.	<ul style="list-style-type: none"><li>* Linea Pro 5 not turned On.</li><li>* Card inserted incorrectly.</li><li>* Swipe method incorrect.</li><li>* Faulty read head.</li><li>* Unreadable magnetic strip.</li></ul>
2	Partial card data returned during swiping.	<ul style="list-style-type: none"><li>* Swipe method incorrect.</li><li>* Faulty read head.</li><li>* Unreadable magnetic strip.</li></ul>

## ***TROUBLESHOOTING - BARCODE SCANNING***

---

If you are having problems scanning barcodes refer to the table below for possible causes.

<b>Item</b>	<b>Problem</b>	<b>Possible Cause</b>
1	Scanner does not turn On.	<ul style="list-style-type: none"><li>* Linea Pro 5 battery is to low.</li><li>* Linea Pro 5 not turned on by software.</li><li>* Faulty scan engine.</li></ul>
2	No barcode data returned during scanning.	<ul style="list-style-type: none"><li>* Unreadable barcode.</li><li>* Linea Pro 5 battery is to low.</li><li>* Faulty scan engine.</li><li>* Software decode incorrectly.</li></ul>
3	Partial barcode data returned during scanning.	<ul style="list-style-type: none"><li>* Unreadable barcode.</li><li>* Linea Pro 5 battery is to low.</li><li>* Faulty scan engine.</li><li>* Software decode incorrectly.</li></ul>
4	Unable to perform multi-scanning.	<ul style="list-style-type: none"><li>* Multi-scan mode not enabled.</li><li>* Software does not support multi-scans.</li></ul>
5	Unable to hear scanner beep.	<ul style="list-style-type: none"><li>* Sound mode not enabled.</li><li>* Linea Pro 5 battery is to low.</li></ul>
6	Unable to scan certain barcodes symbols.	<ul style="list-style-type: none"><li>* Barcode type is not enabled.</li><li>* Barcode type is not supported.</li></ul>

## ***TROUBLESHOOTING - RFID READING/WRITING***

---

If you are having problems reading or writing RFID Tags/Cards refer to the table below for possible causes.

<b>Item</b>	<b>Problem</b>	<b>Possible Cause</b>
1	RFID does not turn On.	<ul style="list-style-type: none"><li>* Linea Pro 5 battery is too low.</li><li>* Linea Pro 5 not turned on by software.</li><li>* Faulty RFID reader.</li></ul>
2	No RFID data returned during reading.	<ul style="list-style-type: none"><li>* Unreadable RFID tag/card.</li><li>* Linea Pro 5 battery is too low.</li><li>* Faulty RFID reader.</li><li>* Software decode incorrectly.</li></ul>
3	Partial RFID data returned during reading.	<ul style="list-style-type: none"><li>* Unreadable RFID tag/card.</li><li>* Linea Pro 5 battery is too low.</li><li>* Faulty RFID reader.</li><li>* Software decode incorrectly.</li></ul>
4	Unable to read certain RFID Tag/Card.	<ul style="list-style-type: none"><li>* RFID type is not compatible.</li><li>* RFID type is not supported.</li></ul>

# **FEDERAL COMMUNICATIONS COMMISSION**

---

## Federal Communications Commission (FCC) Statement

15.21

You are cautioned that changes or modifications not expressly approved by the part responsible for compliance could void the user's authority to operate the equipment.

15.105(b)

This equipment has been tested and found to comply with the limits for a Class B digital device, pursuant to part 15 of the FCC rules. These limits are designed to provide reasonable protection against harmful interference in a residential installation. This equipment generates, uses and can radiate radio frequency energy and, if not installed and used in accordance with the instructions, may cause harmful interference to radio communications. However, there is no guarantee that interference will not occur in a particular installation. If this equipment does cause harmful interference to radio or television reception, which can be determined by turning the equipment off and on, the user is encouraged to try to correct the interference by one or more of the following measures:

- Reorient or relocate the receiving antenna.
- Increase the separation between the equipment and receiver.
- Connect the equipment into an outlet on a circuit different from that to which the receiver is connected.
- Consult the dealer or an experienced radio/TV technician for help.

Operation is subject to the following two conditions:

- 1) this device may not cause interference and
- 2) this device must accept any interference, including interference that may cause undesired operation of the device.

FCC RF Radiation Exposure Statement:

This equipment complies with FCC radiation exposure limits set forth for an uncontrolled environment. End users must follow the specific operating instructions for satisfying RF exposure compliance. This transmitter must not be co-located or operating in conjunction with any other antenna or transmitter.